

Corrugated Steel Pipe is Easy to Install!



CSP *Installation*

Guide

ST 
 **REGIS**

CULVERT INC.

800-527-4604

Introduction

Suggested Use: This Guide is intended to serve as a guidance for the proper installation of CSP.

Liability Statement: The information contained in this CSP Installation Guide is the product of industry experience and practice. The methods used to install CSP can affect both its effectiveness and useful life. The situations described in this booklet and the suggested techniques for installation are general tips and guide lines designed to alert installers and highlight the need for careful review of the on-site conditions. Each installation will require its own evaluation. The statements or descriptions provided in this booklet are information only and the NCSPA assumes no responsibility or liability for their use.

OSHA Procedures Statement: OSHA safety regulations and guidelines must be observed during all phases of construction (Including, but not limited to: foundation preparation, excavation, pipe hauling, assembly and backfill).



**National Corrugated
Steel Pipe Association**

1255 Twenty-Third St., NW, Suite 200
Washington, DC 20037

202.452.1700 • 202.833.3636 (fax)

www.ncspa.org

Contents

1. Unloading & Handling	2
Recommended Equipment	
Unloading	
Handling	
Sizing	
2. Trenches & Pipe Laying	4
Is Your Trench Ready?	
Preparation	
Foundation	
Lay Your Pipe Correctly	
Flow	
Invert Placement	
Shoring	
3. Field Joints	6
4. Gaskets Types	7
Standard CSP Gaskets	
5. Banding	8
Tools Needed	
Common Band Installation Pointers	
6. Multiple Installations	10
Minimum Spacing	
7. Backfill & Depth of Cover	11
Good Backfill is...	
Backfilling	
Pipe Arch Backfilling	
Heavy Construction Loads	

Unloading and Handling

Types of Equipment Recommended:

Since CSP is relatively light weight, it can be handled with light equipment. Use of slings is recommended to properly handle the pipe. CSP should always be lifted and never dragged off of the truck. Proper safety equipment including hard hats, gloves, steel toe shoes and safety glasses should be worn at all times.

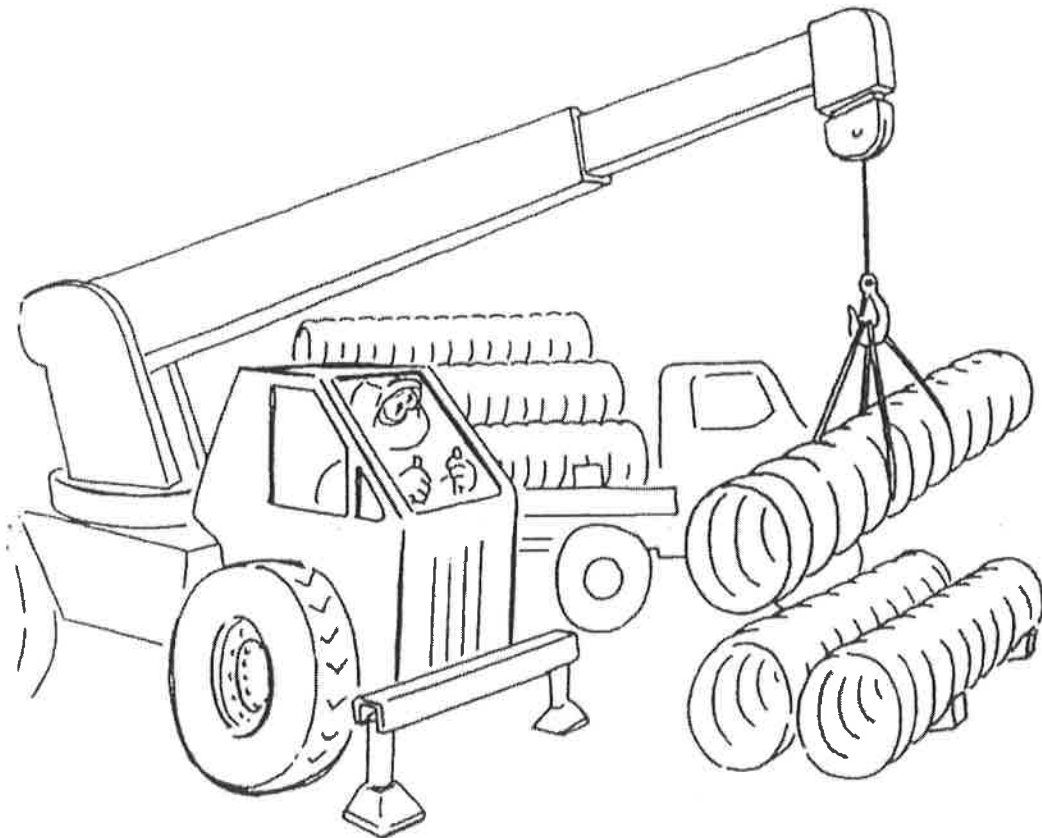

Unloading: Pipe must never be dumped directly from a truck bed while unloading. Dragging the pipe at any time can damage the coatings. Also avoid striking rocks or hard objects when lowering pipe into trenches. If the Pipe has been ordered with lifting lugs, utilize them by using wire rope slings equipped with hooks. When pipe is stacked on truck or ground, make sure stack is properly blocked or strapped.

Handling: Ends may be sharp. Handle with care. Use gloves and the proper protective equipment. Be careful when removing the chains and binders or strapping. It is critical to unload on a level, flat area.

Sizing: Verify quantity, diameter, gauge and length of pipe in accordance with Bill of Lading.

SAFETY WARNING: Never ride on load while lifting or unloading. Clear the area of unauthorized persons.

Trenches & Pipe laying

IS YOUR TRENCH READY?

Preparation: For trench applications the trench width should be 12"-24" wider than the pipe and free of rocks, mud, water, organic matter or frozen lumps of earth. The trench must be wide enough to allow proper backfill of the haunch. Follow OSHA Guidelines. For an embankment installation, controlled backfill zone is 3 x diameter.

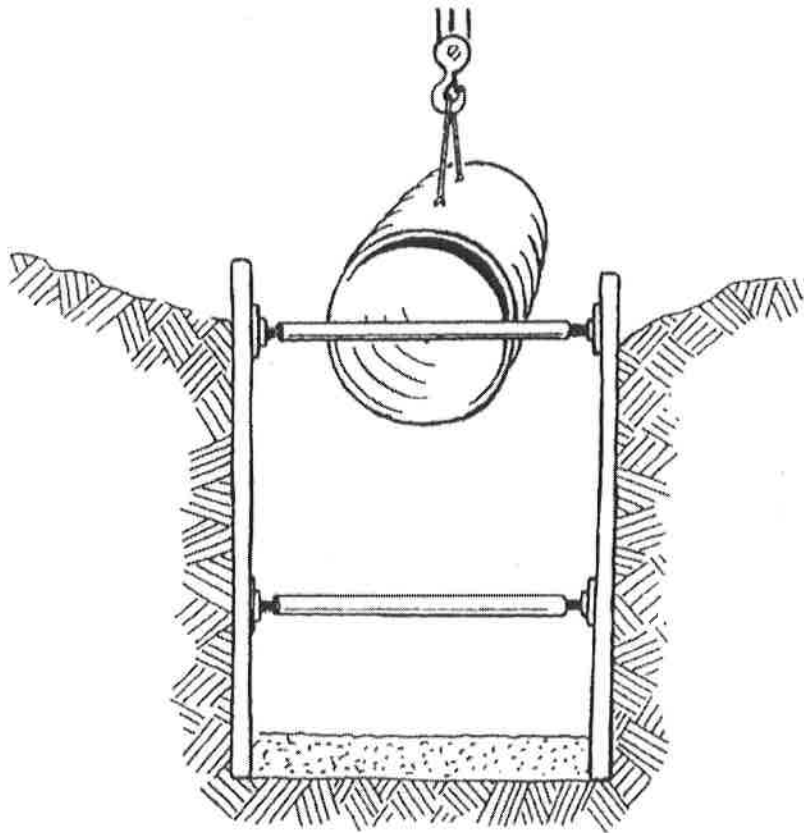

Foundation: All pipe must be placed on stable earth or fine granular foundation. If rock formations are found, they must be removed and replaced with suitably compacted fill. Correct poor

foundations by excavating below grade. Replace with sand, gravel or crushed stone back to proper elevations. Bedding should be smooth and compressible 2"–4".

LAY YOUR PIPE CORRECTLY

Flow: If annular pipe is used, place pipe in the ditch so the inside seam laps point downstream.

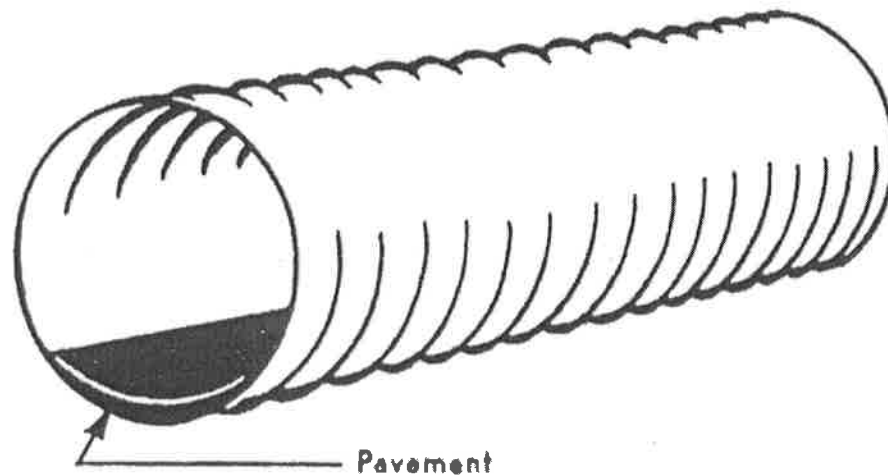
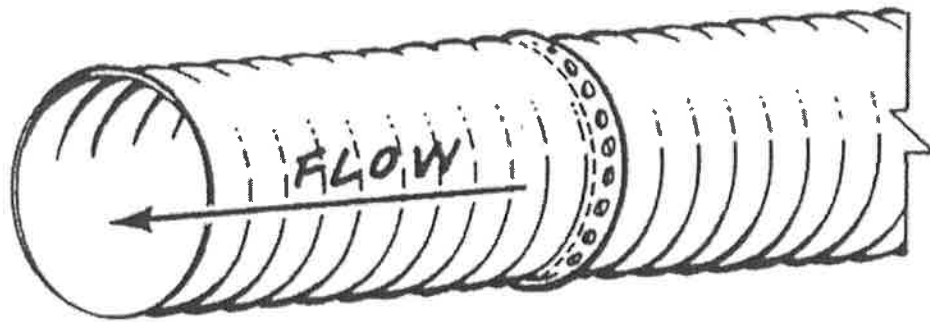

Invert Placement: If paved invert pipe is used, be sure the paving is at the bottom of the pipe.

Shoring: For high fill applications, shoring may be required.

Field Joints

For varying conditions, a variety of different band designs are available.

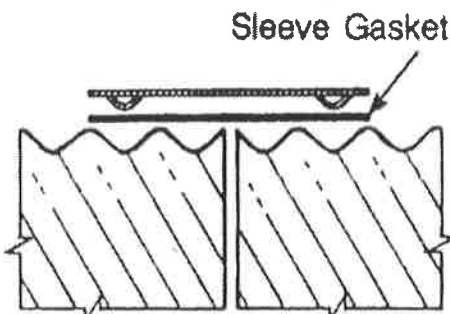
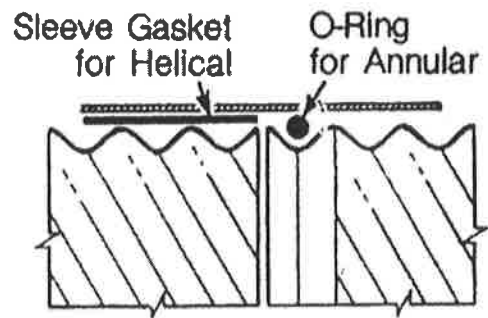
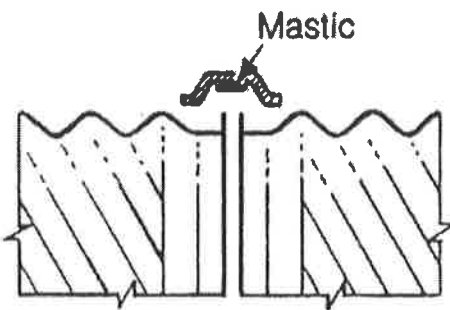
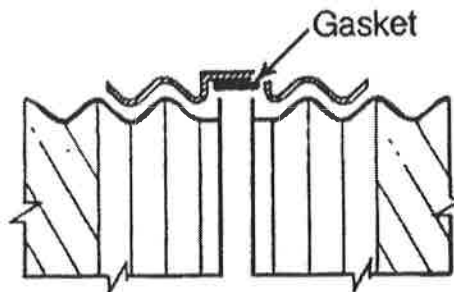
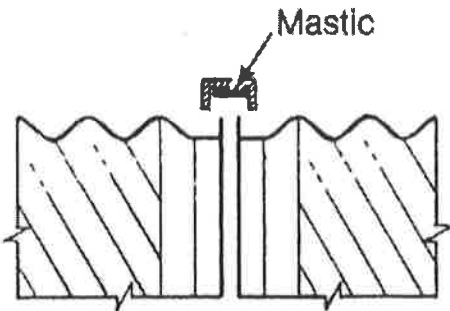
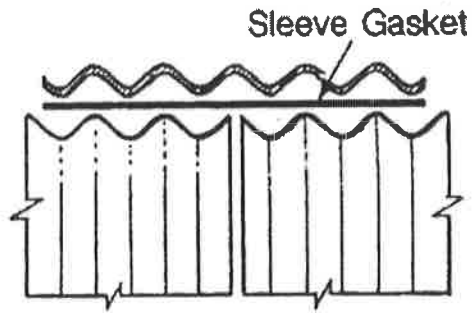
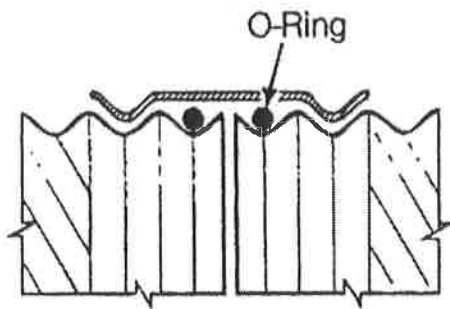

Gasket Types

Standard CSP Gaskets: O-Ring, Sleeve and Strip Gasket. When gaskets are required, they are placed as shown in the previous page.



O-Ring Gasket

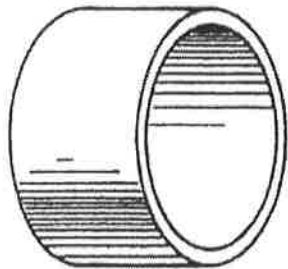

Sleeve Gasket

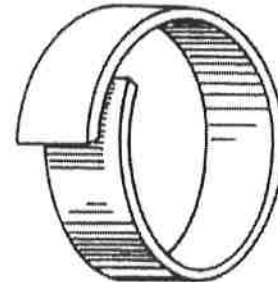

Strip Gasket

Banding

You will need the following tools:

1. 6" x 3/4" ratchet wrench
2. 18" screwdriver or prybar
3. Several large "C" clamps or a band jacket
4. A wooden mallet

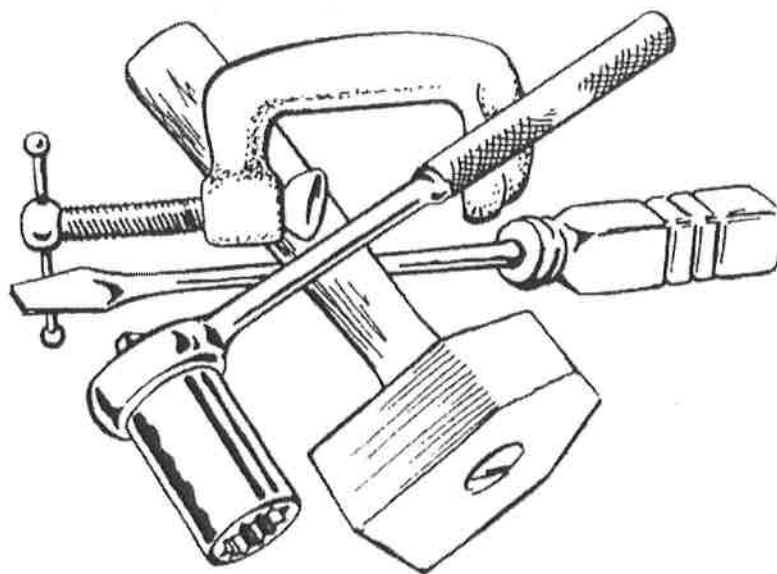

The installation of all bands have many things in common. Some are:

1. Remove any excess asphalt or foreign material from the pipe where you will place the band before putting pipe in the trench.
2. When feasible, place band loosely on one end of the pipe while it is out of the trench.
3. Place pipe in the ditch and remove bedding for 1-2 feet at connection to allow for adjustment while securing bands.

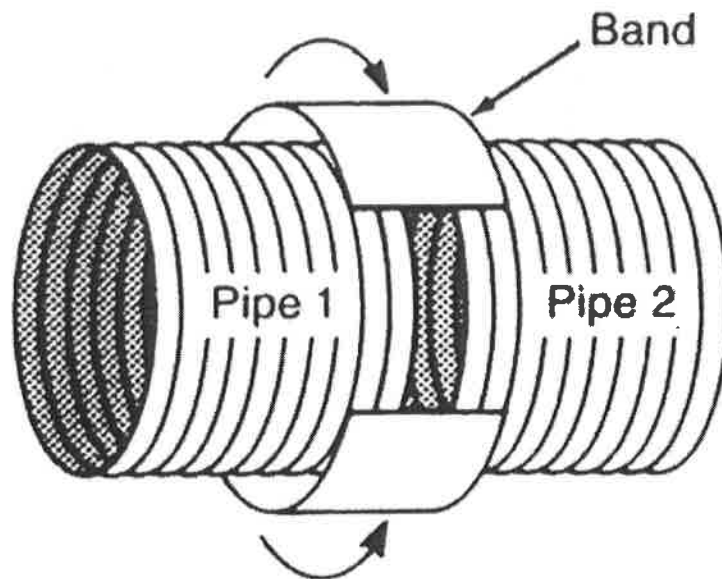

4. Place the other pipe in the band as close together as possible.
5. Use “C” clamps on small pipe and a band jack or come-along on large pipes to help bring the band angles together.
6. When the band angles are close together, put the bolts in the angles and tighten. Keep all nuts at about the same degree of tightness and pressure on the angle.
7. To help seat the band, tap the sides of the band with a wooden mallet.
8. Replace bedding under completed point.

For unusual conditions such as: high pressure; extreme disjuncting forces; threading pipe inside existing pipe; jacking or boring pipe; and deep vertical drop inlets, a variety of special designs are available—or, a new special joint may readily be designed by manufacturers to meet a new requirement.

Multiple Installations

Minimum Spacing: For Round Pipe, Pipe Arches and Arches...

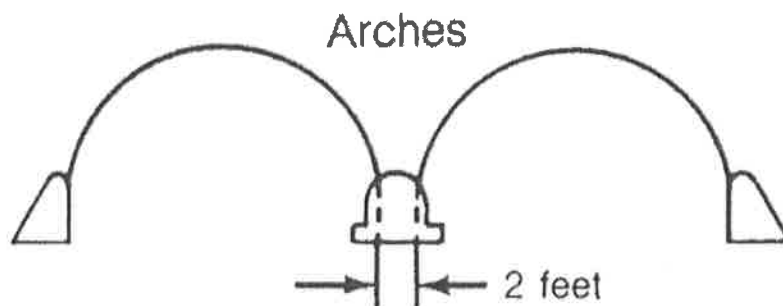
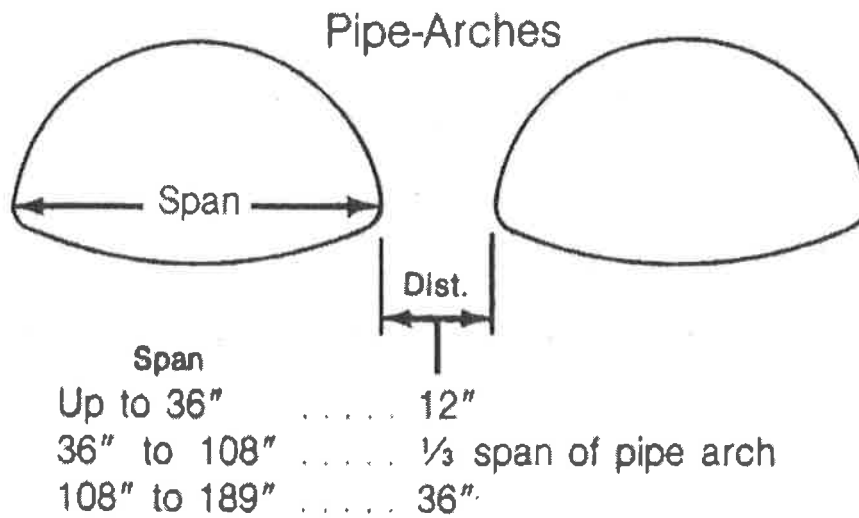
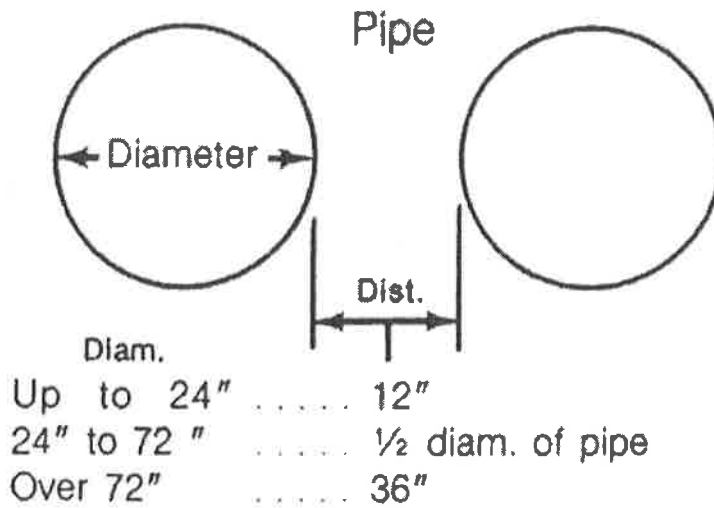

Backfill & Depth of Cover

Good Backfill is... a granular material free from organic or frozen matter. It is easy to grade, free draining and easily compacted.

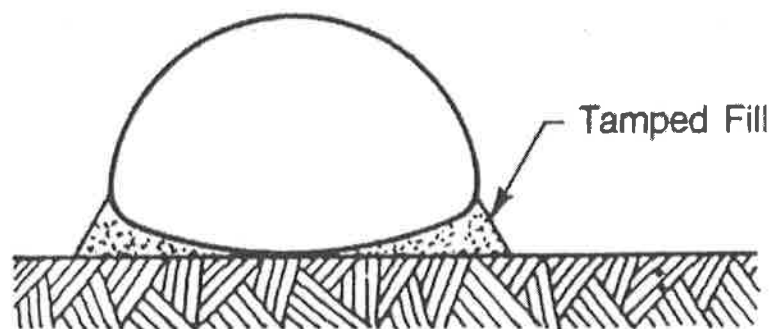
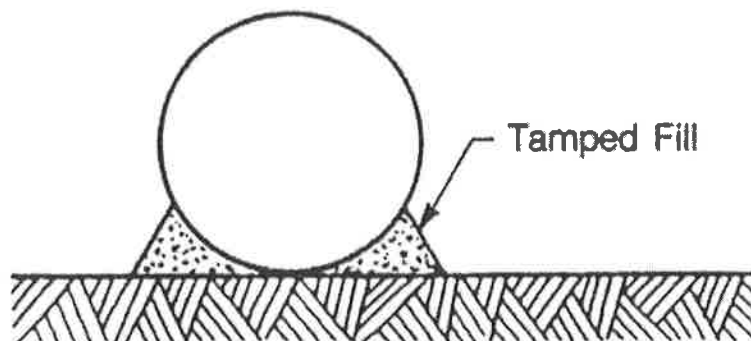
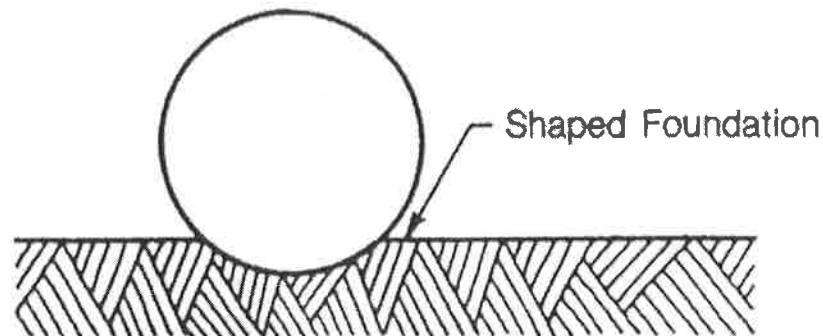

Backfilling: In starting to backfill, be sure material is tamped under the haunches. The minutes you spend tamping now can save days of grief later on. Remove rocks, sod, cinders and frozen lumps

from backfill. Place backfill and compact in 6" layers. Proper compaction means the pipe will carry the specified load.

Pipe Arch Backfilling: Place the fill on the arch by distributing material around and over the structure in uniform layers, tamping thoroughly. Place fill material from top of arch. Filling on one side only will cause the Arch to shift. If fill is not placed on top as backfilling proceeds, arch will raise, flattening side radius. Place backfill on both sides at the same time. Result of not backfilling the trench on both sides simultaneously is a crooked or misaligned pipe.

Heavy Construction Loads: Place at least four (4) feet of cover on top of pipe. The use of heavy construction equipment necessitates greater protection for the structure than finished grade cover minimums. Cover for ramp crossing of heavy construction equipment should be sufficient to prevent damage to drainage structure.

